

## HA 16 X



- 27 ft 9 in (8,45 m) outreach.
- Standard 4 wheel drive.
- 507 lb (230 kg) platform capacity.
- 45% gradeability.



## The Haulotte® advantages

- Maximum height reached in 45 sec.
- 45% gradeability
- Hydraulic differential lock and 15 in (37 cm) ground clearance for demanding rough terrain conditions
- Full proportional controls and simultaneous boom functions improve productivity
- Zero tailswing
- 180° hydraulic platform rotation
- Improved design for travel / transport
- Robust, reliable and easy to maintain design
- Improved security due to load limiter in the basket

## STANDARD FEATURES

- 4 wheel drive and 2 rear steering wheels
- Load limiter in cage
- 5° tilt alarm
- 12 V – 760 A – 92 AH battery / electrical control system
- Battery electric emergency lowering system
- Horn
- Hourmeter
- Free wheeling device
- Mechanical turret slewing lock
- Towing hooks / lifting brackets
- 2 hooks for safety harness in cage

## OPTIONS & ACCESSORIES

- Large basket 91 in x 32 in (2.30 m x 0.8 m)
- Electric power outlet in platform
- On board 3.5 kw generator
- Travel alarm
- Flashing light
- Working light
- Catalytic exhaust
- Biodegradable oil
- Encoded starting device

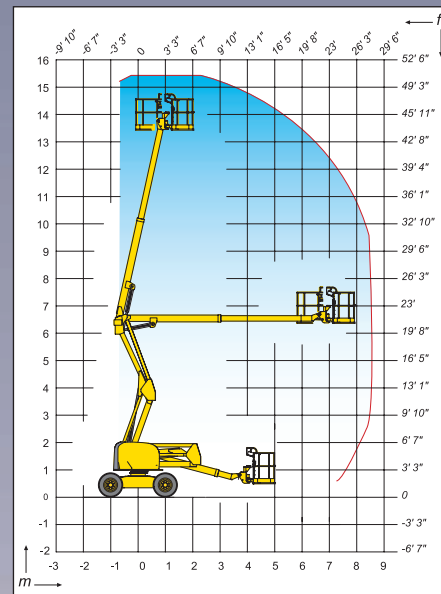
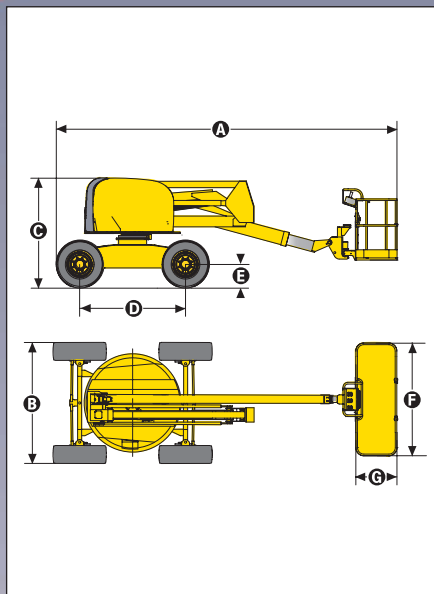

## SPECIFICATIONS

Working height	15.45 m	50 ft 8 in
Platform height	13.45 m	44 ft 2 in
Maximum outreach	8.45 m	27 ft 9 in
Up and over clearance	6.6 m	21 ft 7 in
Maximum capacity	230 kg	507 lb
<b>A</b> Length	6.70 m	22 ft
<b>B</b> Width	2.25 m	7 ft 5 in
<b>C</b> stowed height	2.08 m	6 ft 10 in
<b>D</b> Wheelbase	2.0 m	6 ft 7 in
<b>E</b> Ground clearance	37 cm	15 in
<b>F</b> x <b>G</b> Platform size	1.8 m x 0.8 m	71 in x 32 in
Tailswing	0	
Drive speed	1.5 km/h - 6 km/h	0.9 mph - 3.7 mph
Outside turning radius	9.30 m	30 ft 5 in
Turnable rotation	359°	
Hydraulic platform rotation	180°	
Engine	Deutz Diesel 38 CV - 28 KW	
Gradeability	45%	
Tyres (foam filled)	14 x 17.5	
Hydraulic tank	100 l	22 gal.
Fuel tank	55 l	12 gal.
Weight	6500 kg	14 330 lb

AS1418.10

