

ELECTRIC SCISSOR LIFTS

C10 N
C12
C14

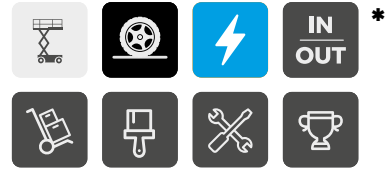

ROBUST AND DURABLE DESIGN

- > Reinforced guardrails with additional vertical support
- > 6mm durable scissors with self-lubricated bush
- > Extra wear-resisting hydraulic hoses
- > 2 layers power coating
- > Special treatment for bolt/pins/bushes to ensure minimum 480h salt spray requirement

LOW TCO

- > Diamond pattern platform floor
- > Common upper control box
- > Charger adapts different charging curve

EASY MAINTENANCE

- > Battery and Hydraulic swing out tray
- > High capacity maintenance free battery

* C10 N & C14: indoor only



ELECTRIC SCISSOR LIFTS

TECHNICAL DATA

	C10 N	C12	C14
Working height	9.75 m	11.75 m	13.75 m
Platform height	7.75 m	9.75 m	11.75 m
Lift capacity - inside	250 kg (2 pers.)	320 kg (3 pers.)	
Lift capacity - outside	NA	320 kg (1 pers.)	NA
Lift capacity on the extension	120 kg		
A Platform length	2.42 m	2.38 m	
B Platform length - extended	3.31 m		
Length - extension	0.92 m	0.94 m	
C Platform width - outside	0.80 m	1.16 m	
D Height - stowed	2.35 m	2.44 m	2.69 m
Height - guardrails lowered	1.97 m	1.72 m	2.05 m
E Overall width	0.81 m	1.20 m	
F Length	2.5 m		
G Wheelbase	1.86 m		
H Ground clearance - center	12.2 cm		
Ground clearance - deployed potholes	2 cm		
Micro Drive speed	0.84 km/h		0.75 km/h
Low Drive speed	2 km/h		
Drive speed	3.6 km/h	3.26 km/h	3 km/h
Gradeability	25 %		
Tilt (longitudinal/lateral)	3° / 1,5°		
Turning radius - outside	2.42 m	2.28 m	
Non-marking tyres	15 x 5		
Batteries	24 V - 220 Ah (C20)	24 V - 265 Ah (C20)	
Hydraulic system capacity	27 l		
Weight	2 150 kg	3 000 kg	3 055 kg

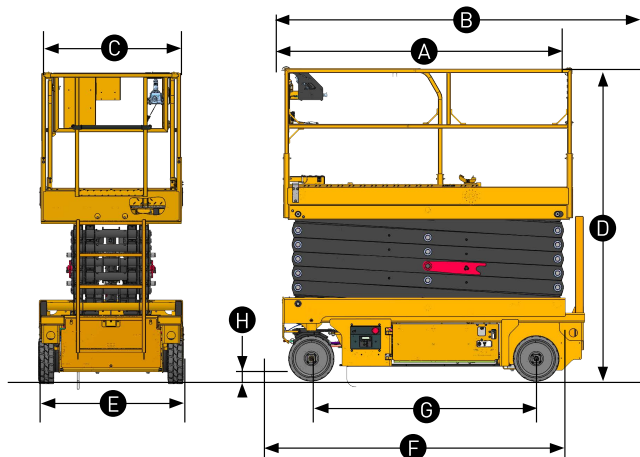

STANDARD EQUIPMENT

- > Front steering & drive wheels
- > Hydraulic motor drive
- > Rear hydraulic brake
- > Powerpack with DC motor
- > Solid non-marking tires
- > 24V AGM Battery pack
- > 24V 30A Charger
- > Mobile upper control box
- > Spiral UCB cable
- > 2 drive speed selector
- > Low control box with cover
- > Battery Swing out tray
- > Powerpack swing out tray
- > Longitudinal forklift pockets
- > Foldable guardrails
- > Front platform extension
- > Drop bar entry
- > Central flashing light
- > Motion alarm
- > Manual emergency descent
- > Hydraulic pothole
- > Tilt alarm
- > Load sensing system

